

MODEL LC-50

LIGHT DUTY

COMMERCIAL FOOD
WASTE DISPOSER

technical essentials

Applications

- Recommended for up to **100 persons per meal**
- Light commercial food waste disposer suitable for:
 - Restaurants
 - Nursing Homes
 - Office kitchens
 - Bed & Breakfast accommodation
- Food waste, including steak bones, can be quickly and efficiently removed

Benefits

- Commercial design with ease and flexibility of domestic unit
- Reduces garbage collection costs
- Speeds clean-ups
- Improves hygiene and sanitation. Major sources of kitchen germs are eliminated with no scraps, no smells and no attraction to insects.
- Environmentally friendly. (Reduces landfill. 100% biodegradable.)

Features

- 1 year full warranty
- Disposer mounting included with unit. Mounting fits standard sink opening (90-100mm). No welding needed.
- Standard wall switch operates disposer
- Automatic reversing motor for longer life and trouble-free operation.
- Stainless steel grind chamber
- Cast nickel chrome cutting elements.

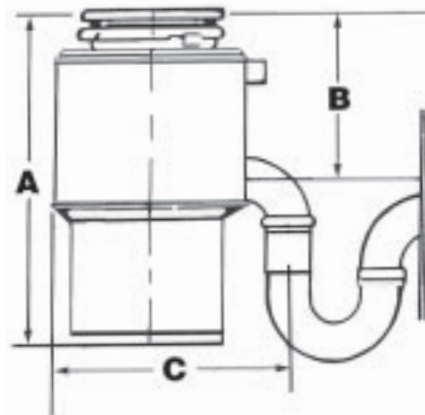

Dimensions

A	362 mm
B	187 mm
C	248 mm

Specifications

Type of Feed	Continuous
On/Off	Wall Switch
Motor	Single Phase
Horsepower	0.50
Volts (V)	240
Hertz (Hz)	50
RPM	1425
Lubrication	Self Lubricating
Unit Finish	Stainless Steel and chrome
Overall Height	362mm
Shipping Weight (approx)	15kg

How to Specify

Food Waste Disposer(s) shall be:
InSinkErator Model LC-50.



AUSTRALIA

1300 136 205

www.insinkerator.com.au

NEW ZEALAND

0800 200 510

www.insinkerator.co.nz



InSinkErator is a division of Emerson Electric Co.

© Copyright 2004.

® Registered trademark of Emerson Electric Co.

™ Trademarks of Emerson Electric Co.

INS11232/LC-50MDG04/04