

# MODEL SS-75

## HEAVY DUTY

COMMERCIAL FOOD  
WASTE DISPOSER

*technical essentials*

### Applications

- Recommended for up to 150 persons per meal
- Heavy duty commercial food waste disposer suitable for:
  - Restaurants
  - Hotels
  - Hospitals
  - Nursing Homes
- Food waste, including steak bones, can be quickly and efficiently removed.

### Benefits

- Reduces garbage collection costs
- Speeds clean-ups
- Improves hygiene and sanitation. Major sources of kitchen germs are eliminated with no scraps, no smells and no attraction to insects.
- Environmentally friendly. (Reduces landfill. 100% biodegradable.)

### Features

- 1 year full warranty
- Standard wall switch operates disposer
- Stainless steel grind chamber
- Cast nickel chrome cutting elements
- Stainless steel & chrome plated finish

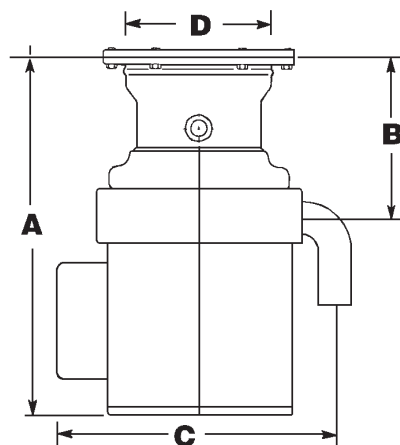

Dimensions	
A	432 mm
B	195 mm
C	335 mm
D	168 mm

### Specifications

Type of Feed	Continuous
On/Off	Wall Switch
Motor	Single Phase
Horsepower	0.75
Volts (V)	240
Hertz (Hz)	50
RPM	1425
Lubrication	Self Lubricating
Unit Finish	Stainless Steel and Chrome
Overall Height	432mm
Shipping Weight (approx)	20kg

### How to Specify

Food Waste Disposer(s) shall be:  
*InSinkErator* Model SS-75.



**AUSTRALIA**  
**1300 136 205**  
[www.insinkerator.com.au](http://www.insinkerator.com.au)

**NEW ZEALAND**  
**0800 200 510**  
[www.insinkerator.co.nz](http://www.insinkerator.co.nz)



*InSinkErator* is a division of Emerson Electric Co.  
© Copyright 2004.  
® Registered trademark of Emerson Electric Co.  
™ Trademarks of Emerson Electric Co.  
INS11232/SS-75MDG04/04