

MODEL SS-150

HEAVY DUTY

COMMERCIAL FOOD WASTE DISPOSER

technical essentials

Applications

- Recommended for up to 300 persons per meal
- Heavy duty commercial food waste disposer suitable for:
 - Restaurants
 - Hotels
 - Hospitals
 - Nursing Homes
- Food waste, including steak bones, can be quickly and efficiently removed.

Benefits

- Reduces garbage collection costs
- Speeds clean-ups
- Improves hygiene and sanitation. Major sources of kitchen germs are eliminated with no scraps, no smells and no attraction to insects.
- Environmentally friendly. (Reduces landfill. 100% biodegradable.)

Features

- 1 year full warranty
- Standard wall switch operates disposer
- Stainless steel grind chamber
- Cast nickel chrome cutting elements
- Stainless steel & chrome plated finish

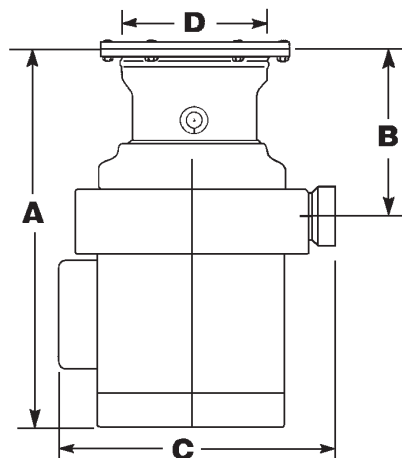

Dimensions	
A	468 mm
B	197 mm
C	360 mm
D	168 mm

Specifications

Type of Feed	Continuous
On/Off	Wall Switch
Motor	Single Phase / Three Phase
Horsepower	1.50
Volts (V)	240
Hertz (Hz)	50
RPM	1425
Lubrication	Self Lubricating
Unit Finish	Stainless Steel and Chrome
Overall Height	468mm
Shipping Weight (approx)	29kg

How to Specify

Food Waste Disposer(s) shall be:
InSinkErator Model SS-150.



AUSTRALIA
1300 136 205
www.insinkerator.com.au

NEW ZEALAND
0800 200 510
www.insinkerator.co.nz



InSinkErator is a division of Emerson Electric Co.
© Copyright 2004.
® Registered trademark of Emerson Electric Co.
™ Trademarks of Emerson Electric Co.
INS11232/SS-150MDG04/04